

BASTET – A MASCOT-STYLE NANOLANDER INVESTIGATING THE SUBSURFACE OF APOPHIS, SEISMICITY, AND TIDAL FORCES DURING EARTH ENCOUNTER

Tra-Mi Ho⁽¹⁾, Jan Thimo Grundmann^{(1)*}, Jens Biele⁽²⁾, Christian Krause⁽²⁾, Stephan Ulamec⁽²⁾, Matthias Grott⁽³⁾, and the BASTET Team

⁽¹⁾*DLR German Aerospace Center, Institute of Space Systems, Robert-Hooke-Strasse 7, 28359 Bremen, Germany*

**corresponding coauthor +49-(0)421-24420-1107, jan.grundmann@dlr.de*

⁽²⁾*DLR German Aerospace Center, Microgravity User Support Center (MUSC), Linder Höhe 1, Köln, Germany*

⁽³⁾*DLR German Aerospace Center, Institute of Planetary Research, DLR, Rutherfordstraße 2, 12489 Berlin, Germany*

Keywords: *Apophis, RAMSES, wideband radar sounding, wideband seismometry, MASCOT*

Abstract

The concept of a ≈10 kg “nanolander” equipped with a customized suite of instruments designed to complement its carrier spacecraft’s science has been proven valuable e.g. with the Mobile Asteroid Surface sCOuT (MASCOT) surface science package on JAXA’s HAYABUSA2 mission. MASCOT successfully landed and operated on (162173) Ryugu on October 3rd, 2018, bridging the gap between the results of orbiter instruments and samples returned to Earth. MASCOT2, a photovoltaic-powered long-life derivate was studied in 2015/16 foreseen to be part of ESA’s proposed AIM mission, to be deployed on Dimorphos in advance of DART’s impact. Unlike the primary battery powered MASCOT, it would have been able to support long-term operations allowing to map the 3D internal structure and geophysical properties of the asteroid by ground-penetrating radar and accelerometers. MASCOT2 in the Didymos system served as the basis of self-transfer MASCOT studies which included propulsion to increase flexibility regarding possible restrictions of various carrier missions. Another variant, CALICUT, was studied to be part of a Chinese asteroid mission to the active asteroid, 133P/Elst-Pizarro, aimed at a long-term operation of the scientific instruments, including a camera, a gamma-ray-spectrometer, a wideband ground-penetrating radar, and a MultiScience Package (MSP) containing a magnetometer, a radiometer, an electric field sensor experiment, a neutral density gauge, an accelerometer, and a set of ground penetrators (“Darts”). In order to cope with the lower solar flux at main belt distances, the lander was designed to have almost 3 times the volume of MASCOT but remained at 13 kg integrated mass. A much wider portfolio of further studies has been performed for various proposed small solar system body missions, including fast fly-by support packages e.g. in a flotilla concept for NEOTwIST as well as adaptations for very

small host spacecraft, e.g. resources-sharing concepts. ESA’s proposed RAMSES mission – via HERA a “grandchild” of AIM – inspired a fresh interpretation of the MASCOT2 idea benefiting from a decade of progress in instrument development enabling an expanded set of instruments as well as extensive re-use of MASCOT spare parts, to design and build a self-transfer nanolander within a short timeframe in the spirit and haste of a planetary defense mission now only 3 years from launch towards a very brief encounter before Earth; MASCOT took 2 years to develop from PDR to FM delivery. A wide-band ground penetrating radar, a seismometer, a gravimeter, an accelerometer, and the proven instruments of MASCOT would perform this investigation of the subsurface of Apophis, Seismicity and Tidal forces in Earth encounter (BASTET). Every potentially impacting NEO will experience the same deflection effects as MASCOT2 would have measured on Dimorphos during and after the DART impact, and it will experience a close Earth fly-by, naturally or after deflection. Thus, every rendezvous reconnaissance mission can benefit from its own investigations of the subsurface of its Asteroid, Seismicity and Transient effects of Energy Transfers.

Introduction

The concept of a ≈10 kg “nanolander” equipped with a customized suite of instruments designed to complement its carrier spacecraft’s science has been proven valuable e.g. with the Mobile Asteroid Surface sCOuT (MASCOT) surface science package on JAXA’s HAYABUSA2 mission. [1,2,3]. MASCOT successfully landed and operated on (162173) Ryugu – formerly 1999 JU₃ – on October 3rd, 2018, bridging the gap between the results of orbiter instruments and samples returned to Earth. [4,5,6] The discovery of the smaller-scale topography and conditions on the surface of the asteroid has shown how in-situ observations can not only bridge a gap in science but also

9th IAA Planetary Defense Conference – PDC 2025 5-9 May 2025, Stellenbosch, Cape Town, South Africa

de-risk operations of the larger carrier spacecraft of a nanolander, and inform the detailed planning, in particular of close approach manoeuvres or landing site selection, of the ongoing mission as well as the design of future missions to follow.

Many MASCOT derivative concepts for various proposed small solar system body missions have meanwhile been studied, perhaps most prominently MASCOT2 for the ESA mission AIM [7] to (65803) Didymos and Dimorphos, and CALICUT for a possible Chinese Asteroid Mission by the CNSA to the active main belt asteroid 133P/Elst-Pizarro [8].

The MASCOT concept and design of a dependable platform for several fully planetary science grade instruments can be adapted to the various specific technical and scientific requirements of rendezvous and fly-by missions to asteroid Apophis in 2029, embedded within and networking with the whole ecosystem of observations and missions currently taking shape. It can uniquely complement remote observations by spacecraft in rendezvous, such as ESA's planned RAMSES mission or NASA's OSIRIS-APEX mission, in fast fly-by such as currently envisaged for JAXA's DESTINY+ mission and the JANUS pair of NASA spacecraft, in relatively slow encounter as may be enabled by advanced propulsion concepts such as solar sails, and by ground-based assets such as planetary radar and radio science, possibly even telescopic observations if Apophis should become active during its close encounter with Earth – to name just one of the many known unknowns in a one-in-a-hundred-lifetimes (1-in-7500 years) event.

MASCOT – the Mobile Asteroid Surface Scout

The original MASCOT (Mobile Asteroid Surface sCOuT) flown on the HAYABUSA2 mission had a landed mass of 9.64 kg and a size of 292 x 278 x 208 mm³, with just over 11 kg fly-away system mass. It was attached to the mother spacecraft via a recessed MESS (Mechanical and Electrical Support Structure) to eject the lander towards the microgravity target, Ryugu. [9] MASCOT carried four scientific instruments: MicrOmega [10], MASCAM [11], MARA [12], and MASMAG [13] (Figure 1, top). MASCOT communicated through the multi-lander operations communication subsystem of HAYABUSA2 which in total carried 12 deployable elements: 4 landers (MINERVA-II-1A HIBOU and MINERVA-II-1B OWL deployed on September 21st, 2018, operating for 36 and 3 days, respectively, on photovoltaic power; MASCOT released on October 3rd, 2018 for 17 hours of surface operations on non-rechargeable battery; and MINERVA-II-2 ROVER-2 deployed on October 2nd, 2019, into asteroid orbit to explore Ryugu's gravitational environment for 6 days until it landed by perturbations), 2 active sub-spacecraft (the Small Carry-on Impactor (SCI) and the Deployable Camera (DCAM3) to create an artificial impact crater and observe its formation), 5 highly

reflective but otherwise passive 'bean bag' target markers (2 used for sampling touch-downs; 1, each, released for gravity field exploration into equatorial and polar orbit, completing the first constellation outside the Earth-Moon system; 1 still aboard for the planned encounter with 1998 KY₂₆ in July 2031), and the sample capsule returned to Earth on December 6th, 2020. During the delivery of the samples, HAYABUSA2 set course for a fast fly-by at (98943) Torifune (previously 2001 CC₂₁) in July 2026, continuing as the HAYABUSA2# ('SHARP' - Small Hazardous Asteroid Reconnaissance Probe) mission.

MASCOT2 – jumping on DART's target

MASCOT2 was a photovoltaic-powered long-life derivate design of the MASCOT nanolander studied in 2015/16 as part of ESA's proposed AIM mission, [7] to be deployed on Dimorphos, the moonlet of (65803) Didymos, a binary near-Earth asteroid system. In contrast to the short primary battery lifetime of MASCOT of only 17 h, a longer lifetime of the lander was required to allow a long-term science operation on the asteroid to determine the 3D internal structure as well as further geophysical properties by ground-penetrating radar tomography [14,15] and accelerometers. The ground-penetrating bistatic low-frequency radar was to be complemented by a monostatic high frequency radar operating from the carrier spacecraft, only.

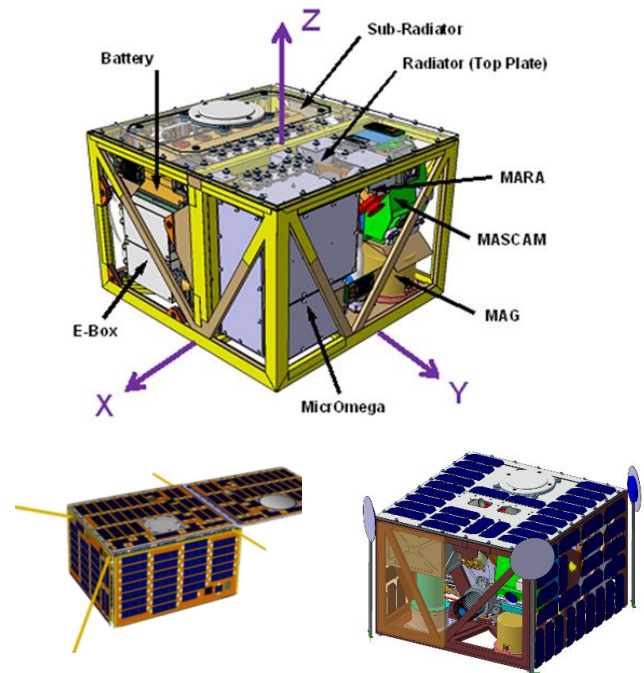

Figure 1: MASCOT nanolander aboard the HAYABUSA2 mission (top, enlarged). MASCOT2 nanolander design for the AIM/ESA mission (lower left) and CALICUT nanolander concept for the Chinese Asteroid Mission/CNSA (lower right) approx. to scale

9th IAA Planetary Defense Conference – PDC 2025 5-9 May 2025, Stellenbosch, Cape Town, South Africa

To enable long-term lander operations on the asteroid(s) surface(s), MASCOT2 carried photovoltaic generators as well as rechargeable batteries (Figure 1, lower left); its volume increased to 329 x 297 x 208 mm³ and total mass (including MESS) to ≈15 kg.

Compared to the recessed MESS design for MASCOT (Figure 2, left), the MESS of MASCOT2 is flat allowing a more flexible accommodation of the nanolander on any spacecraft (Figure 2, right).

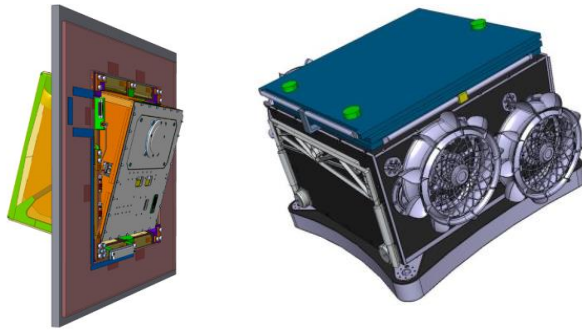

Figure 2: MESS of MASCOT in HAYABUSA2 spacecraft (left). Pizza-box-sized MECSS under IDEFIX rover mounted on JAXA's MMX spacecraft, structure derived from MASCOT2 MESS structure (right).

This served as the basis for the structure attaching the IDEFIX rover to JAXA's MMX spacecraft [16]. AIM was canceled in 2016 because of insufficient funding. It was replaced with the similar HERA mission without MASCOT2, but the concept of long-wavelength or multi-band radar tomography has prevailed and remained on the mission in the shape of a smaller cubesat, JUVENTAS, carrying the JuRa low-frequency radar. [17]

CALICUT – activities in the asteroid belt

CALICUT (Figure 1, lower right), was a nanolander design studied as part of the Chinese Asteroid Mission (CAM, ZHENGHE) to the active asteroid 133P/EIst-Pizarro [8] which could also be applied for missions to targets of a similar character or/and aphelion distance. The CAM mission, as almost all current mission proposals, also aimed at a long-term operation of the scientific instruments. In order to cope with the lower solar flux at the aphelion distance of distant main belt objects, the volume reached 392 x 378 x 308 mm³ although total mass was limited to 13 kg including MESS. CALICUT was designed to carry a suite of smaller instruments, i.e. a camera, a gamma-ray-spectrometer, a wideband ground-penetrating radar, and a Multi-Science Package (MSP) containing a magnetometer, a radiometer, an electric field sensor experiment, a neutral density gauge and an accelerometer. The MSP also included a set of ground penetrators ("Darts") to be catapulted into the ground by a recoil-less mechanism, to support the electric field and thermal environment experiments. The reaction masses

ejected at the same time contained tracking equipment to explore the gravity field. These instruments are not restricted to main belt or active small solar system bodies and could be applied on many other target objects, as well.

By the dozens – MASCOT general studies

A much wider portfolio of further nanolander studies [7] has been performed for various proposed small solar system body missions, including fast fly-by support packages e.g. in a flotilla concept for NEOTwIST as well as adaptations for very small host spacecraft, e.g. resources-sharing concepts. The science payload fraction of MASCOT-style nanolandings usually exceeds 35% and can be as high as 50%. Most of the generated electrical energy is available for the science payload, and high-power instruments are supported by a large battery for cyclic operation, alternating with recharging phases.

In general, the main science payload is comprised of one or two relatively large instruments or topical synergetic complementary sets like the CALICUT MSP. It is supported by a stable set of smaller instruments for landing and operating sites context and relocation tracking which link it to the orbiter's observations which include MasCam, MARA, MasMag and accelerometers.

The various studies have focused on such diverse topics as composition, volatiles, the coma, regolith studies, gravity, seismicity, and the interior structure. The mobility of a MASCOT-style nanolander can cover these at several locations, and it can also observe their evolution over time or in relation to a specific event such as DART's impact on Dimorphos which would have been witnessed by MASCOT2 from a distance of <89 m.

BASTET for Apophis and Planetary Defense

Based on RAMSES' currently estimated closest approach distances of 5 km above the surface of Apophis prior to the close Earth encounter, [18,19] BASTET carries thrusters to enable the longer travel/descent distance to the asteroid surface. [20,21] A flat MESS derived from the MASCOT2 design is the mechanical interface between the BASTET lander and the RAMSES spacecraft. The electrical and communication interface is provided by a Data Relay Subsystem (DRSS) which can be shared with more than one MASCOT-style nanolander or other separable sub-spacecraft, e.g. similar to the HAYABUSA2 mission's complement of task-specific sub-spacecraft, or carried by other spacecraft to the same target, and even including sample-retrieval or -return landers. [22-28]

BASTET will keep much of the original MASCOT concept such as the carbon fiber reinforced structure, an excentre mass for mobility attached to a common electronic box. A slight increase in size depending on the power requirements of the subsystems and scientific

9th IAA Planetary Defense Conference – PDC 2025 5-9 May 2025, Stellenbosch, Cape Town, South Africa

payloads might be required, taking advantage of the lower gravity of Apophis compared to Ryugu. (Figure 3) ESA's proposed RAMSES mission – via HERA a “grandchild” of AIM – inspired a fresh interpretation of the MASCOT2 idea benefiting from a decade of progress in instrument development enabling an expanded set of instruments as well as extensive re-use of MASCOT spare parts, to design and build a self-transfer nanolander within a short timeframe in the spirit and haste of a planetary defense mission now only 3 years from launch towards a very brief encounter before Earth; MASCOT took 2 years to develop from PDR to FM delivery. [29,30]

A wide-band ground penetrating radar, [14,15,17] a seismometer, [31] a gravimeter, [32] an accelerometer, [7] and the surface context science instruments of MASCOT [11-13] would perform this investigation of the subsurface of Apophis, Seismicity and Tidal forces in Earth encounter (BASTET, also the name of the Egyptian goddess of fertility, contrasting Apophis).

BASTET science instruments

Although no definite selection has been made, yet, the system and accommodation study demonstrated, that a comprehensive set of instruments can be carried and operated even when using the original MASCOT Flight Spare structure or the MASCOT2 structure detailed design. Moreover, *all* candidate scientific instruments that have co-evolved in time with the progress of NEO science, the preparations for the Apophis close encounter with Earth, and MASCOT-style nanolander evolution from MASCOT2 for Dimorphos towards Apophis could be accommodated:

- **Mission Main Instrument (MMI): Apophis Interior Structure Exploration (ApolSE) asteroid properties observation multi-sensor package & teams:**
 - **Radar / radio waves frequency spectrum section:**
 - Wideband Ground-Penetrating Radar & Altimeter (**WGPR/A**, Plettemeier et al.)
 - synergetic support from the communication subsystem (DLR GSDR in BASTET & DRSS aboard host spacecraft)
 - **Seismic / tidal / gravity forces frequency spectrum section:**
 - **Low frequency and gravity component sensor:** GRAvimeter for Small Solar system bodies (**GRASS**, Karatekin et al.)
 - **Medium frequency and seismic range sensor:** Seismic Instrument for Asteroids (**SIA**, Murdoch et al.)
 - **High frequency and accelerations range sensors:** MASCOT Multi-channel Advanced MEMS Array tetraedric Accelerometer (**MA³tAcc**, Biele et al.)
 - synergetic support from the GNC subsystem's IMU & Star Trackers (University of Würzburg)

- excitation source support from the Mobility Subsystem
- **Surface and Context Science Instruments (SCSI) set & teams:**
 - MASCOT Magnetometer (**MasMag**, Plaschke et al.)
 - MASCOT Radiometer (**MARA**, Grott et al.) with improved sensor head
 - MASCOT Camera (**MasCam**, Schmitz et al.) with enhanced LED illumination
 - synergetic support and imaging from the GNC subsystem's Star Trackers
 - shared use of MA³tAcc acceleration sensors & GNC IMU while bouncing
 - shared use of GNC orientation and proximity sensors for ambient data

BASTET beyond Apophis for Planetary Defense

BASTET was originally developed to complement and augment the observations of Apophis that rendezvous spacecraft can provide from a distance with occasional close slow fly-bys [18,19] or by sampling its surface materials [22-25]. It adds to these activities a long-term on-asteroid segment which investigates the interior of Apophis and takes repeated close-up high-resolution observations of a small area of the surface before, during and after the close Earth encounter of Friday, April 13th, 2029. Even after the end of operations of its carrier spacecraft due to fuel exhaustion, it can provide long-term science and asteroid tracking with a direct link to Earth.

It may well be obvious, but *any* NEO concerning planetary defense has *at least one* very close encounter with Earth – upon its discovery, on the final leg towards potential impact, and more often than not several times in-between. The same tasks and capabilities that are required for the scientific study of Apophis before, during and after close encounter are also required for the rendezvous characterization of a NEO considered dangerous enough to visit; for shepherding it through close encounters and past possible keyholes; before, during and after deflection (akin to MASCOT2 which most likely would have stared DART in the eye from the near-side of Dimorphos); or before an inevitable impact to characterize the impactor as best as possible for preparation and bracing oneself down here on Earth.

Conclusion

The MASCOT-style nanolander BASTET originally developed for ESA's rendezvous mission, RAMSES, would not only complement the observations taken by 'orbiters' during Apophis' close encounter with Earth in 2029. It can serve as a template for a dependable long-term operating surface element for planetary defense.

9th IAA Planetary Defense Conference – PDC 2025
5-9 May 2025, Stellenbosch, Cape Town, South Africa

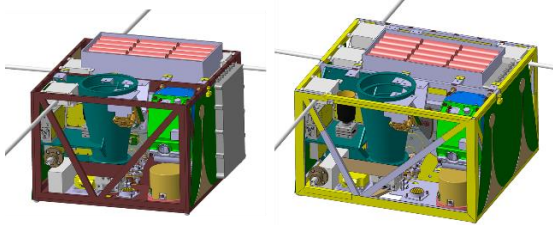

Figure 3: Two accommodation studies of BASTET, using the envelopes of MASCOT (left) and MASCOT2 (right) as baseline.

References:

- [1] Watanabe, S. et al., Hayabusa2 arrives at the carbonaceous asteroid 162173 Ryugu—A spinning top-shaped rubble pile (2019) *Science Vol 364, Issue 6437*, pp. 268-272, doi: 10.1126/science.aav8032.
- [2] Ho, T.-M. et al., MASCOT—The Mobile Asteroid Surface Scout Onboard the Hayabusa2 Mission. *Space Science Review* 208, 339–374 (2017), doi: 10.1007/s11214-016-0251-6.
- [3] Krause, C. et al. (2022). MASCOT—A Mobile Lander On-board the Hayabusa2 Spacecraft—Operations on Ryugu. In: Cruzen, C., Schmidhuber, M., Lee, Y.H. (eds) *Space Operations*. Springer Aerospace Technology. Springer, Cham, doi: 10.1007/978-3-030-94628-9_25
- [4] Jaumann, R. et al., Images from the surface of asteroid Ryugu show rocks similar to carbonaceous chondrite meteorites, (2019) *Science Vol 365, Issue 6455* pp. 817-820, doi: 10.1126/science.aaw8627.
- [5] Grott, M. et al., Low thermal conductivity boulder with high porosity identified on C-type asteroid (162173) Ryugu. *Nat Astron* 3, 971–976 (2019), doi: 10.1038/s41550-019-0832-x.
- [6] Herčík, D. et al., Magnetic Properties of Asteroid (162173) Ryugu, (2020) *Journal of Geophysical Research: Planets, Volume 125, Issue 1*, doi:10.1029/2019JE006035.
- [7] Lange, C. et al., MASCOT2 – A small body lander to investigate the interior of 65803 Didymos' moon in the frame of the AIDA/AIM mission, (2018) *Acta Astr.* Volume 149, August 2018, Pages 25-34, doi: 10.1016/j.actaastro.2018.05.013.
- [8] Ho, T. M. et al., A nanolander for a space mission to an active asteroid in the main belt, (2023) *Acta Astr.* Volume 213, December 2023, Pages 49-70, doi: 10.1016/j.actaastro.2023.08.024.
- [9] Grimm, C. et al., The MASCOT Separation Mechanism - A Reliable, Low-Mass Deployment System for Nano-Spacecraft, (2020) *CEAS Space Journal* (12), Seiten 343-365, doi: 10.1007/s12567-020-00302-y
- [10] J.-P. Bibring et al., The MicrOmega Investigation Onboard Hayabusa2, *Space Sci Rev* (2017) 208:401–412, doi: 10.1007/s11214-017-0335-y
- [11] Jaumann, R. et al., The Camera of the MASCOT Asteroid Lander on Board Hayabusa 2, *Space Sci Rev* 208, 375–400 (2017), doi: 10.1007/s11214-016-0263-2
- [12] Grott, M. et al., The MASCOT Radiometer MARA for the Hayabusa 2 Mission, *Space Sci Rev* 208, 413–431 (2017), doi: 10.1007/s11214-016-0272-1
- [13] Herčík, D. et al., The MASCOT Magnetometer, *Space Sci Rev* 208, 433–449 (2017), doi: 10.1007/s11214-016-0236-5
- [14] Herique, A. et al. (2018) Direct observations of asteroid interior and regolith structure: Science measurement requirements. *Advances in Space Research* (62), pp. 2141-2162. Elsevier. doi: 10.1016/j.asr.2017.10.020
- [15] Herique, A. et al. (2019) A radar package for asteroid subsurface investigations: Implications of implementing and integration into the MASCOT nanoscale landing platform from science requirements to baseline design, *Acta Astronautica*, Volume 156, March 2019, Pages 317-329, doi: 10.1016/j.actaastro.2018.03.058
- [16] Michel, P. et al. (2022) The MMX rover: performing in situ surface investigations on Phobos. *Earth Planets Space* 74, 2 (2022), doi: 10.1186/s40623-021-01464-7.
- [17] Herique A. et al., Radar to Apophis: Probing the Interior of 99942 Apophis with Cubesats, Apophis T-4, 2025, #2045, <https://www.hou.usra.edu/meetings/apophis2025/pdf/2045.pdf> and references therein.
- [18] Michel P. et al., Science Objectives of RAMSES: ESA's Rapid Apophis Mission for SpacE Safety, Apophis T-4, 2025, #2012, <https://www.hou.usra.edu/meetings/apophis2025/pdf/2012.pdf>
- [19] Martino P. et al., Operational Design of RAMSES: ESA's Rapid Apophis Mission for SpacE Safety, Apophis T-4, 2025, #2013, <https://www.hou.usra.edu/meetings/apophis2025/pdf/2013.pdf>
- [20] Chand, S. (2020) <https://elib.dlr.de/143958/>.
- [21] Ho T.-M. et al., BASTET – A MASCOT-Style Nanolander Investigating the Subsurface of Apophis, Seismicity, and Tidal Forces During Earth Encounter, Apophis T-4, 2025, #2051, <https://www.hou.usra.edu/meetings/apophis2025/pdf/2051.pdf>
- [22] Hilchenbach M. et al., Grabbing a sample from a real Near-Earth Asteroid (NEA): A very fast Sample Return Mission opportunity, IAA-PDC-25-07-57 (*this conference*)
- [23] Kleine T. et al., Fast Sample Return from Near-Earth Asteroids, Apophis T-4, 2025, #2035, <https://www.hou.usra.edu/meetings/apophis2025/pdf/2035.pdf>
- [24] Grundmann J. T. et al., APOSSUM – A Fast Sample Return for a Near-Earth Asteroid: There and Back Again with a System, Apophis T-4, 2025, #2052,

**9th IAA Planetary Defense Conference – PDC 2025
5-9 May 2025, Stellenbosch, Cape Town, South Africa**

<https://www.hou.usra.edu/meetings/apophis2025/pdf/2052.pdf>

[25] Goldmann M. et al., APOSSUM – A Fast Sample Return for a Near-Earth Asteroid: Sampling and Storage, Apophis T-4, 2025, #2054, <https://www.hou.usra.edu/meetings/apophis2025/pdf/2054.pdf>

[26] Grundmann et al., (2017) Small Landers and Separable Sub-Spacecraft for Near-term Solar Sails, <https://elib.dlr.de/118803/>

[27] Grundmann et al., (2019) Capabilities of GOSSAMER-1 derived Small Spacecraft Solar Sails carrying MASCOT-derived Nanolandings for In-Situ Surveying of NEAs, doi: 10.1016/j.actaastro.2018.03.019, <https://elib.dlr.de/121945/>

[28] Spietz et al., (2021) Paths not taken - The GOSSAMER roadmap's other options, doi: 10.1016/j.asr.2021.01.044, <https://elib.dlr.de/141755/>

[29] Grimm, C., et al., From idea to flight - A review of the Mobile Asteroid Surface Scout (MASCOT) development and a comparison to historical fast-paced space programs, (2018) *Progr. in Aerosp. Sci.* Volume 104, January 2019, Pages 20-39, doi: 10.1016/j.paerosci.2018.11.001.

[30] Grimm, C. & Hendrikse, J. (2019) Concurrent AIV as a Method to hard tailor Test- and Model Philosophies in Times of Need. *MethodsX* (6), Seiten 2148-2155. Elsevier. doi: 10.1016/j.mex.2019.08.010

[31] Murdoch N. et al., Seismic Instrument for Asteroids (SIA): A Geophone-Based Instrument for RAMSES, Apophis T-4, 2025, #2036, <https://www.hou.usra.edu/meetings/apophis2025/pdf/2036.pdf>

[32] Noeker, M., Ritter, B., Van Ransbeeck, E. et al. Design, manufacturing, and assembly of the GRASS small body gravimeter spring. *CEAS Space J* (2024). doi: 10.1007/s12567-024-00574-8